

- All Plastic Construction
- Perfect for Pump Protection
- Flow | No | Low Flow Notification

Ryton

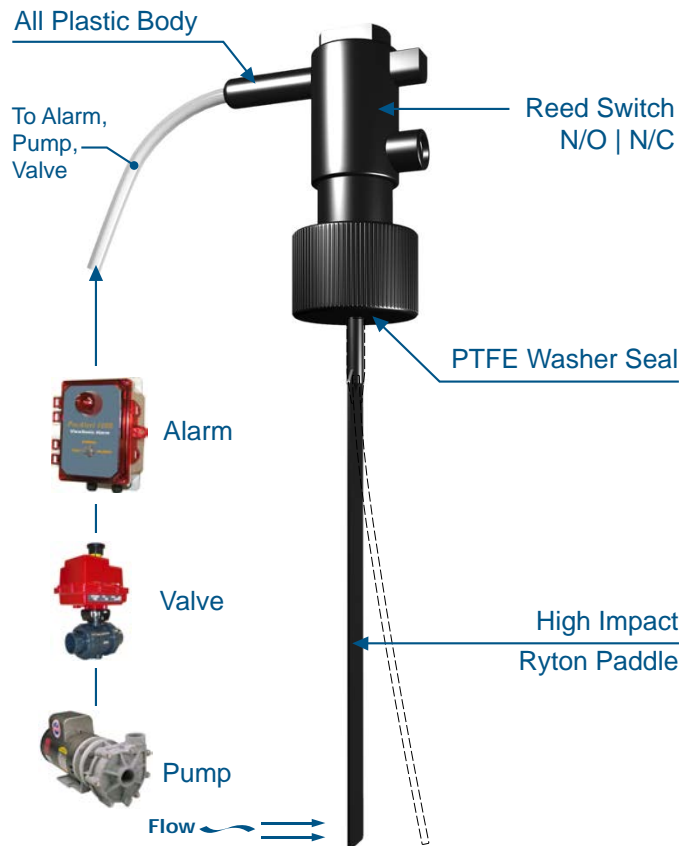

**SERIES : UFS**  
**CONNECTION : 3/4" NPT**  
**Seal : PTFE**



### Description

The Heavy Duty Truflor UFS Series flow switch is easy to install and offers excellent chemical resistance and reliability. The UFS Series is available with a normally open or normally closed reed switch contact. The nominal switching point is determined by the length of the paddle. During installation, the paddle is typically cut at a mark based upon the pipe diameter, equating to the highest possible switch sensitivity and lowest switching point. Installation is easy; simply insert the UFS Flow Switch into an appropriately sized Tee fitting.



Universal - Trim to Desired Length  
 Can be done Easily in the Field  
 Simple to Install

### FEATURES

- Excellent Chemical Resistance
- Size Range | 1" - 16"
- Easy to Install | Simply mount switch into Plastic Tee Fitting
- Excellent Mechanical Properties
- High Pressure Rating | Up To 150 psi
- High Wear Resistance
- Heavy Duty Design
- No Power Required
- 3/4" Spigot PVC Adapter Fitting (Optional)

### SPECIFICATIONS

Pipe size	1" - 16"
Sensor Body Paddle	RYTON
Electrical Connection	2 Wire
Viscosity Range	0.5 to 20 Centi Stoke (cst)
Maximum Particle Size	<10% with Particle Size (<0.5mm cross section or length) Recommend Strainer If Larger
Maximum Operating Pressure/Temperature	150 psi @ -30 to 100°C
Cable	3 ft (Std) * Longer Lengths Available
Max. Power	1 Amp

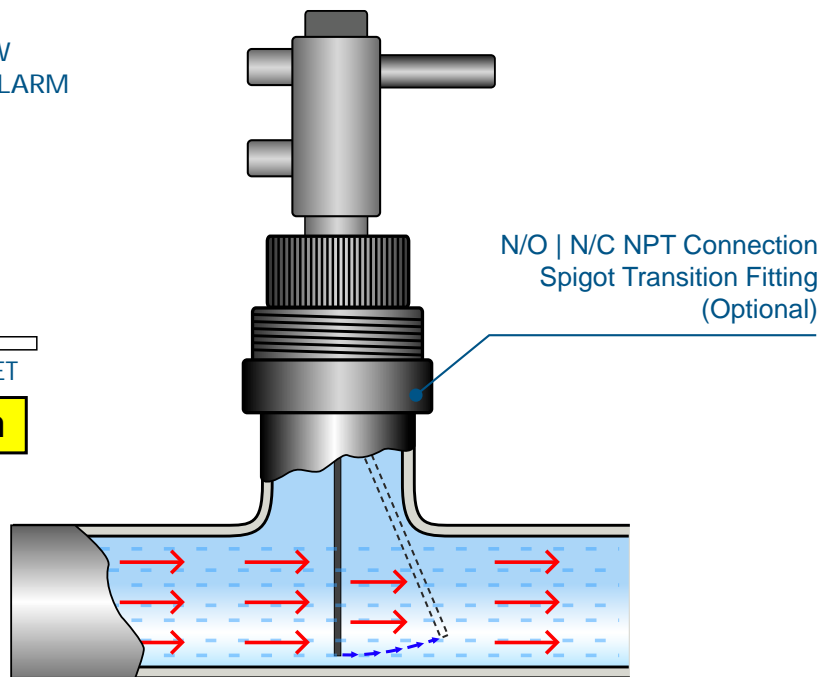
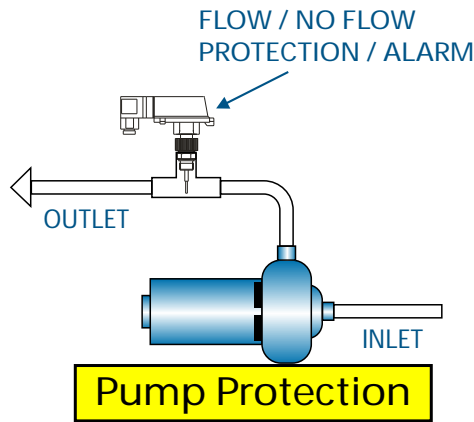

Perfect for Pump Protection

Dimensions

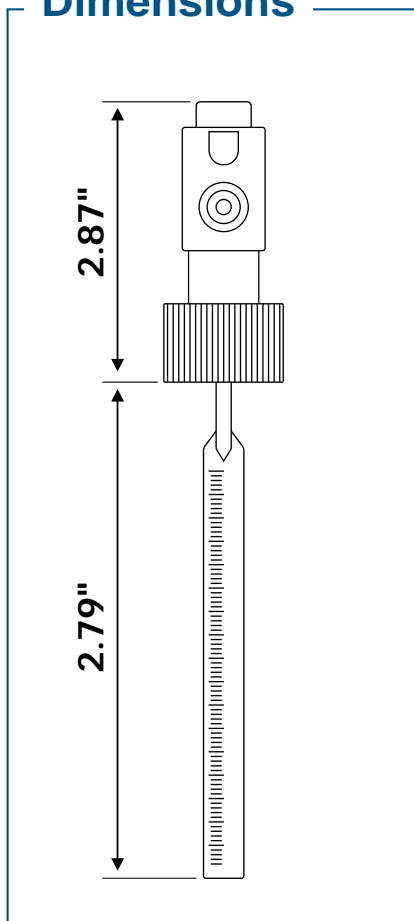

PVC and CPVC Pipes - Schedule 40		PVC and CPVC Pipes - Schedule 80	
Normal Pipe Size (Inches)	Approximate Switching Point (GPM)	Normal Pipe Size (Inches)	Approximate Switching Point (GPM)
1/2	1.9	1/2	1.5
3/4	3.3	3/4	2.7
1	5.4	1	4.5
1-1/4	9.3	1-1/4	8.0
1-1/2	12.7	1-1/2	16.0
2	21.0	2	18.4
2-1/2	30.0	2-1/2	21.4
3	46.0	3	41.0
4	79.0	4	72.0
5	124.0	5	113
6	180.0	6	162
8	312.0	8	385
10	492.0	10	448
12	697.0	12	634.0
14	843.0	14	765.0
16	1100.0	16	1003.0